

※鍊條輸送帶寬度可調整
Chain-conveyor width can be changed.

特色: Features:

- 軌道寬度可調結構
Changeable width mechanism.
- 升降機構協助放/取料
Workpiece lifter.
- 適用於圓柱棒材型工件
For bar-shaped workpiece.

ATPFD-0D 鍊條式供料機-Chain Type

項目 Item	規格 Specification
工件尺寸 Workpiece Size	外徑:Ø 30mm (圓柱工件)
儲存數量 Storage Quantity	40 Pcs (標準數量)
佔地面積 Space Occupied	On Demand

※以上數值均為參考規格，可依照客戶需求變更設計。
Above specification can be changed depended on customer requirement.



鍊條式供料機

運用範例
Example

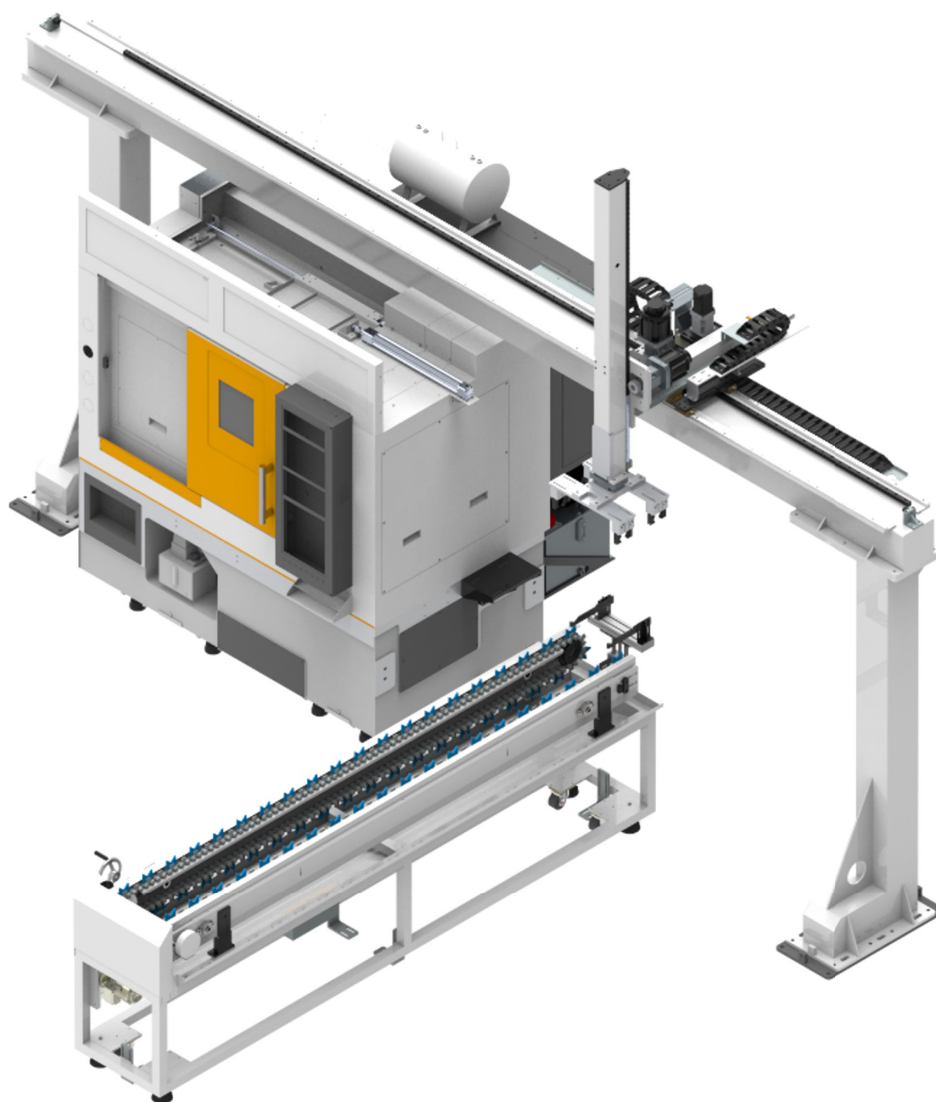

升降機構
Lifter

V型塊
V-Block

鍊條驅動
Chain-Conveyor

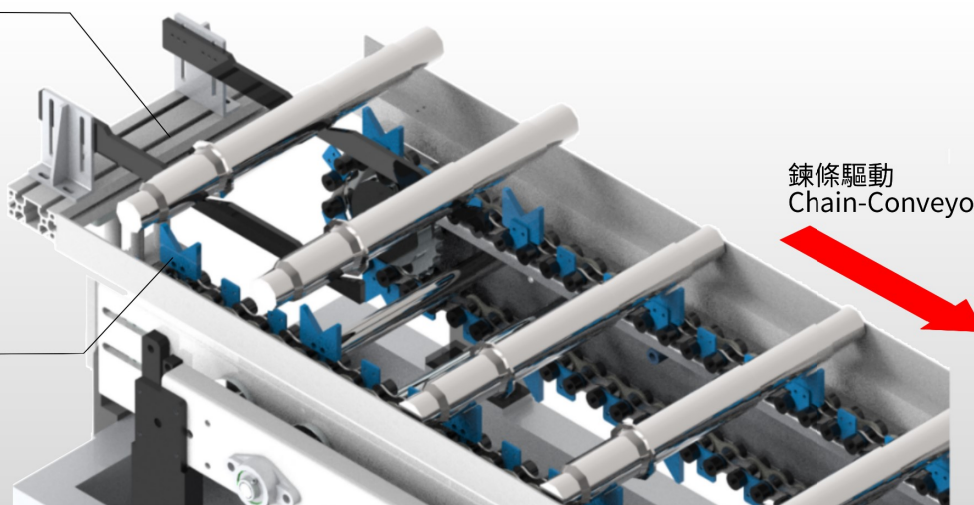

※以上圖片僅供參考，請以實際出貨設備/設計為準。

All Pictures shown are for illustration purpose only. Actual product/design may vary due to product enhancement.